



Main features:

- Complete system for the simultaneous strain-measurement on up to four tie bars
- Direct display of strain values in $\mu\epsilon$, kN or t (via our Inspectmate software or Sensormate App)
- Wireless transmission (2.4GHz), no cables
- Quick and non-destructive assembly with magnetic press-on technology
- High accuracy and linearity in tension and pressure (like bonded strain gauges)
- Ideal for use on presses, injection-moulding and die-casting machines
- Application on tie bars with a diameter of 45mm or higher and flat surfaces
- Dynamic applications
- Each magnetic-mount strain sensor has an integrated signal amplifier
- Integrated rechargeable battery with up to 8h operating time
- Receiver with USB interface or receiver with bluetooth 5 low energy interface
- Very compact and easy to use system

The magnetic strain gauge sensor QE1008-W measure the surface-strain directly at the mounting location in the same quality as bonded strain gages. The magnetic press-on technology, developed by Sensormate AG, presses the strain gauges under the stainless protective film so strongly against the surface to be measured that frictional contact occurs.

The mounting of the sensor is non-destructive, very fast and simple. The integrated signal amplifier with wireless transmission module makes the QE1008-W a state-of-the-art sensor with unsurpassed features and user-friendliness.

TECHNICAL DATA SENSOR

Strain gauge type	Foil (GF = 2.0)
Bridge resistance	350 Ω
Measuring range	$\pm 800\mu\epsilon$
Output signal for radio transmission	IEEE 802.15.4TM
Signal range	Up to 100m (depending to operating area)
Sensitivity tolerance	$\pm 0.2\%$
Transverse sensitivity	0.9 \pm 0.2 %
Accuracy	< $\pm 0.5\%$ FS
Linearity	< $\pm 0.5\%$ FS
Hysteresis	< $\pm 0.5\%$ FS
Repeatability	< 0.2% FS
Operating power consumption	2x 1.2VDC (2x AAA rechargeable battery)
Charger power consumption	100...230VAC
Ambient temperature	5...65°C
Storage temperature	0...65°C
Overload capability	unlimited
Type of protection	IP40
Material: Housing	Aluminium
Material: Cover	Plastic
Weight	530g

TECHNICAL DATA TRANSCEIVER-MODULE

	QE1008-W-USB-G	QE Booster
Max. pairable sensors	8	8
Power supply	External via USB (5.0 VDC-500 mA)	Stand alone with integrated lithium battery
Connector type	USB-A male	USB-C female
Battery type	-	LiPo 3.7V 340 mAh
Battery life	-	12 h
Charging time	-	~ 2 h
Charging requirements	-	USB (5.0 VDC-500 mA)
Protection class	IP40	IP40
Case material	Plastic	Plastic + holding magnets
Weight	100g	50g

TECHNICAL DATA TRANSMISSION

	QE1008-W-USB-G	QE Booster
Frequency	2.4000-2.4835 GHz (ISM-Band)	2.4000-2.4835 GHz (ISM-Band)
Protocol sensor to transceiver	IEEE 802.15.4TM	IEEE 802.15.4TM
Protocol transceiver to end device	USB 2.0	Bluetooth 5
End device compatibility	Windows XP/7/8/10	Android 4.3 (Bluetooth 4) or newer
TX-power	0dBm / 1 mW (max.)	0dBm / 1 mW (max.)
Range	For IEEE 802.15.4TM theoretical up to 100m (Typ. 30 m)	"For IEEE 802.15.4TM theoretical up to 100m (Typ. 30 m) For Bluetooth 5 theoretical up to 300m (Typ. 30 m) "
„The transmission module is FCC (USA), IC (Canada), ETSI (Europe) and TELEC (Japan) certified. The MAC address is always unique and burnt into the hardware.“		

DIMENSIONS SENSOR

QE1008-W

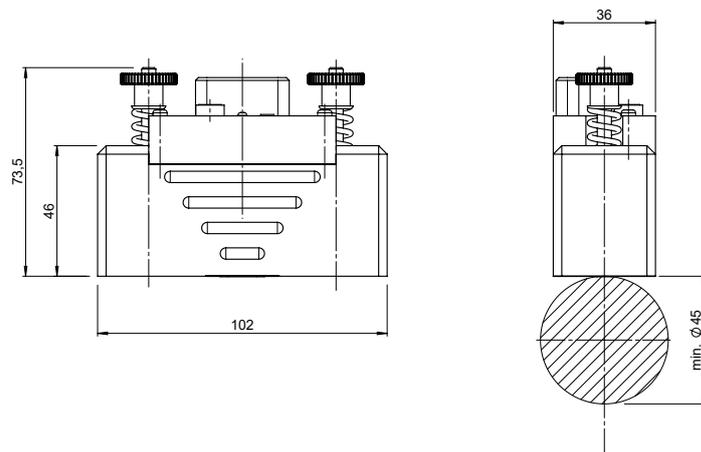

Dimensions in mm

DIMENSIONS USB TRANSCEIVER-MODULE

QE1008-W-USB-G

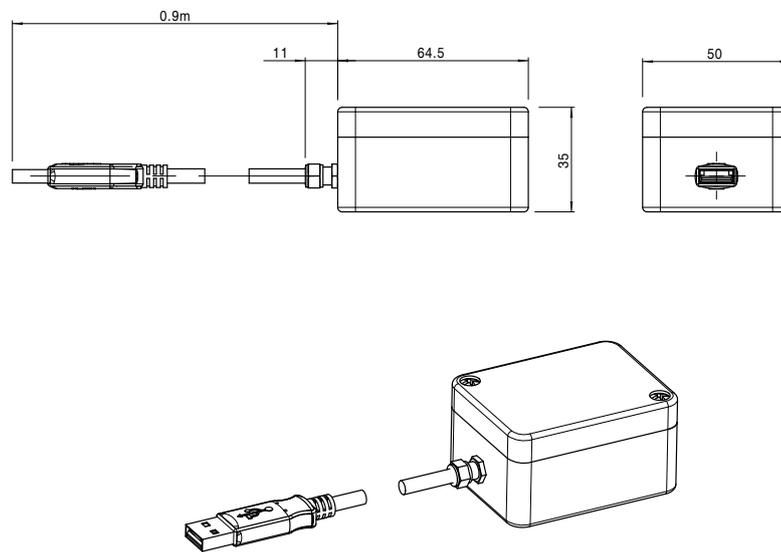

Dimensions in mm

DIMENSIONS BLUETOOTH TRANSCEIVER-MODULE

QE Booster

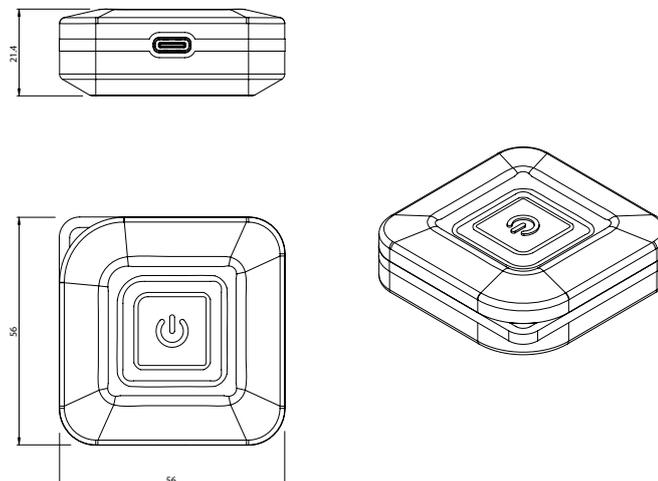

Dimensions in mm

APPLICATION

QE1008-W-SET

- Very flexible system for measuring tie bars and also flat surfaces.
- Detecting cracks on tie bars.
- No steel bands or other mounting aids are required.

System containing with two sensors:

- „USB“ or „Bluetooth transceiver-module“
- 2 magnet-mount strain sensors QE1008-W incl. rechargeable batteries
- Carrying case with inserts, manual
- Alignment software, Inspectmate

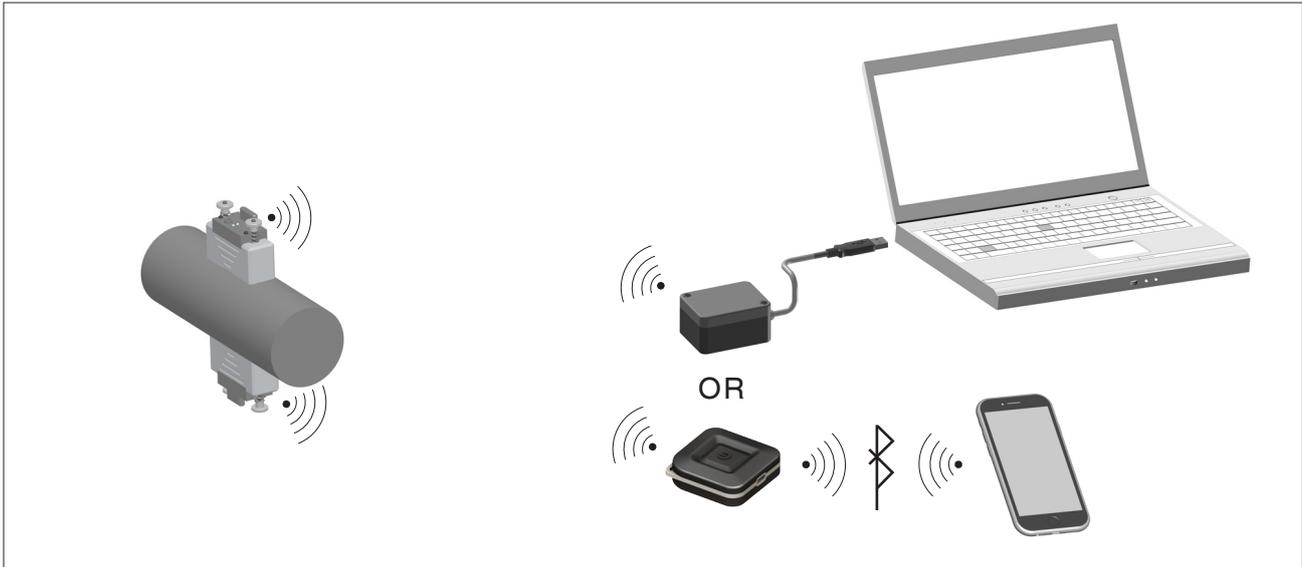

External dimensions of carrying case	340 x 280 x 130 mm
Weight approx.	ca. 3 kg

System containing with 4...10 sensors:

- „USB“ or „Bluetooth transceiver-module“
- 4...10 magnet-mount strain sensors QE1008-W incl. rechargeable batteries
- Carrying case with inserts, manual
- Alignment software, Inspectmate

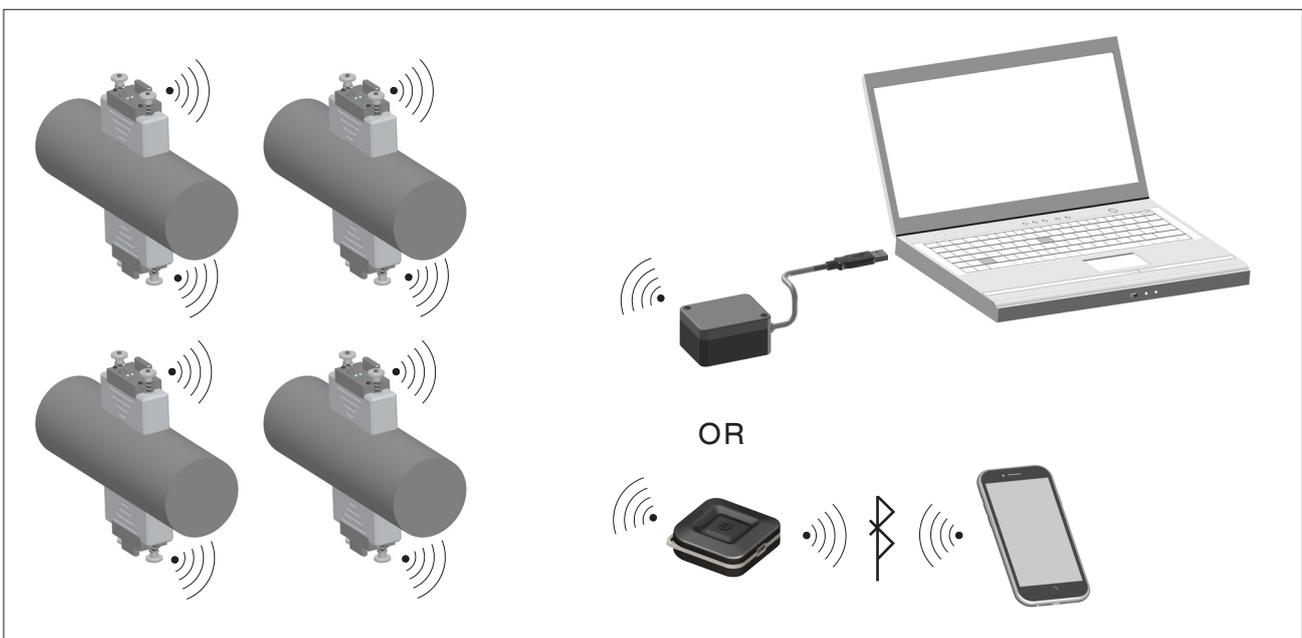

External dimensions of carrying case	400 x 320 x 130 mm
Weight approx.	ca. 6 kg

ORDER CODE

Magnet mount strain sensor
complete system

QE1008 -



Connection	
Wireless	W

Number of sensors	
2 pieces	02
4 pieces	04
8 pieces	08
9 pieces	09
10 pieces	10

Transceiver - Module	
USB	USB
Bluetooth	BLE

Example: QE1008-W-08-BLE

Magnet-mount strain sensor QE1008, wireless, number of sensors = 8 pieces, with bluetooth transceiver-module

ACCESSORIES

Description	Order code	Code
Magnet-mount strain sensor	QE1008-W	F065869
USB transceiver-module	QE1008-W-USB-G	F061962
Bluetooth transceiver-module	QE Booster	F081356
Charge bar	CB-4-QE1008-W	F062885
Charger for charge bar	POWER SUPPLY	F069657
Repair-Kit foil	REPAIR-KIT FOIL	F060472

GEFRAN spa reserves the right to make any kind of design or functional modification at any moment without prior notice.



Sensormate AG

Steigweg 8, - CH-8355 Aadorf, Switzerland
ph: +41(0)52-2421818 - fax: +41(0)52-3661884
Internet: <http://www.sensormate.ch>



GEFRAN spa

via Sebina, 74 - 25050 PROVAGLIO D'ISEO (BS) - ITALY
ph. +39 030 9888.1 - fax. +39 030 9839063
Internet: <http://www.gefran.com>