



INFRARED CAMERAS

The most portable infrared online cameras in the world

innovative infrared technology

Important features of the infrared cameras

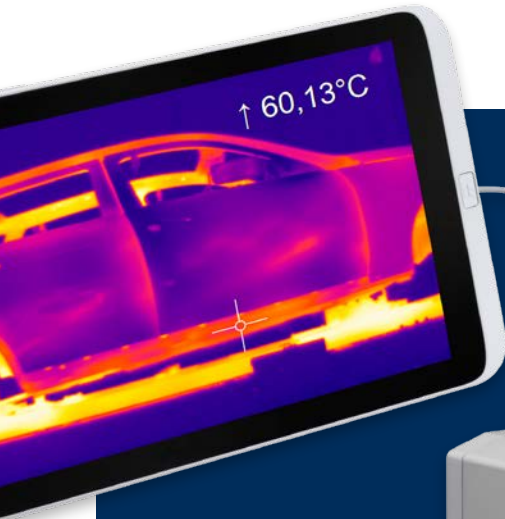

Made in Germany

2 years
warranty

Special advantages

- Temperature ranges from $-20\text{ }^{\circ}\text{C}$ to $1800\text{ }^{\circ}\text{C}$
- Small cameras ideal for OEM use
- Up to 1 kHz for fast processing
- Optical resolution up to 764×480 pixels
- Includes license-free analysis software and full SDK

Automatic hotspot search

Objects can be thermally analyzed and **hot or cold spots** can be automatically found.

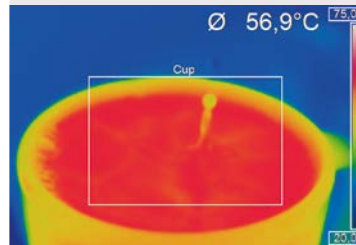
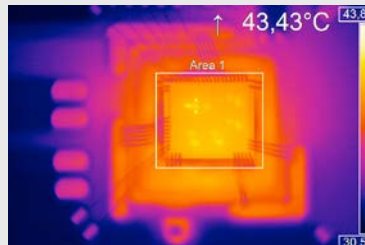

A drop of milk falling into a cup of coffee

Portable and stationary

The cameras bridge the existing gap between portable infrared snapshot cameras and purely stationary devices.

Examples of areas of application are:

- **Process automation**
- **Test stations**
- **Research & development**
- **Mobile measuring jobs**

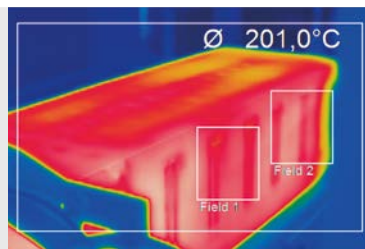

Simple process integration

Advanced interface concepts enable integration into networks and automated systems:

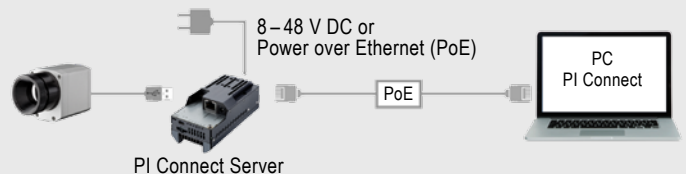

- USB cable extension up to 100 m (over Ethernet)
- Industrial Process Interface (PIF) with two analogue inputs, one digital input and over three analogue outputs/alarm outputs with three isolated relays ($0-30\text{ V} / 400\text{ mA}$); additional fail-safe relay.
- Software Development Kit (SDK) for integration of the camera into customer-specific software via Dynamiclink Library (DLL) or COM-Port.

optris® PI 160

INFRARED CAMERA WITH 120 Hz FRAME RATE

innovative infrared technology

Small camera ideal for OEM use

- Outstanding value for money
- Very good thermal sensitivity from 80 mK
- Thermal image in real time with up to 120 Hz
- Thermal analysis kit including 3 lenses (optional)
- Detector with 160 x 120 pixels
- Compact design (dimensions: 45 x 45 x 62 mm)
- Includes license-free analysis software and full SDK



Surface measurements in industrial application

The optris® PI 160 infrared camera is always used when temperature monitoring of surfaces is required and the single point measurement of pyrometers is no longer sufficient.

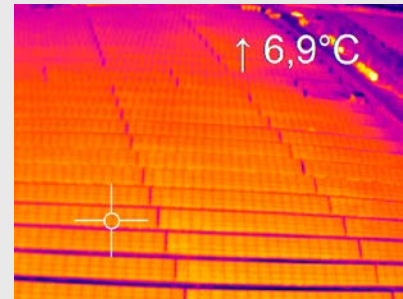

Nowadays surface measurements are essential in the automotive field, in plastic applications and in the solar industry.

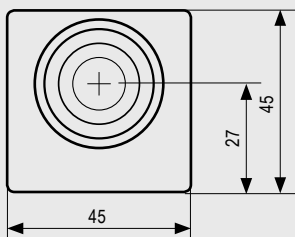
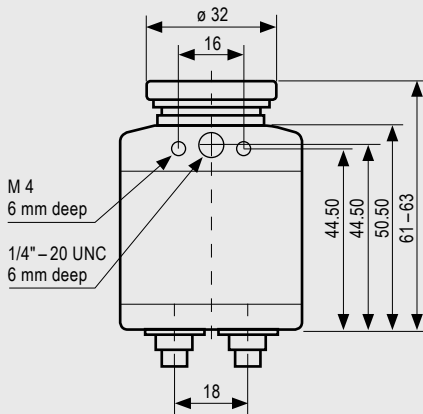

Dimensions in mm

Suitable lenses for every measurement distance

Same measurement field size at different measurement distances:

- Wide-angle lens:
0.27 m measurement distance
- Standard lens:
0.6 m measurement distance
- Telephoto lens:
2.13 m measurement distance

Hand as measurement object:
measurement field size 240 mm x 180 mm
pixel size 1.5 mm

160 x 120 pixels

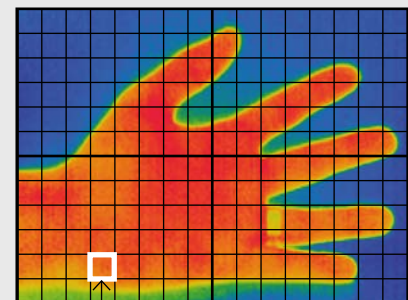

10 x 10 pixels = 225 mm²

optris® PI 200 / PI 230

INFRARED CAMERA

WITH BI-SPECTRAL TECHNOLOGY

Two cameras
in one
compact device

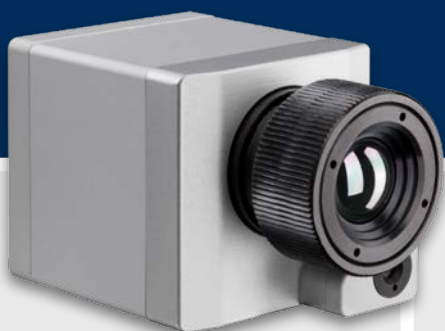

- BI-SPECTRAL Technology
- Time-synchronized real image recording at up to 32 Hz (640 x 480 pixels)
- Real image camera is highly sensitive in low-light conditions
- Thermal images in real time at up to 128 Hz (160 x 120 pixels)
- Compact design (dimensions: 45 x 45 x 62 mm)
- Thermo analysis kit including 3 lenses (optional)
- Includes license-free analysis software and full SDK

BI-SPECTRAL Technology

With the help of BI-SPECTRAL technology a **real image (VIS)** can be combined with a **thermal image (IR)** and plotted synchronistically:

Surveillance mode:

Easy orientation at the measuring point through separate display of the visual picture.

Crossfade mode:

Highlight critical temperatures by means of crossfade (transparency from 0 to 100 %) or by means of superimposition of defined temperature fields (thresholds).

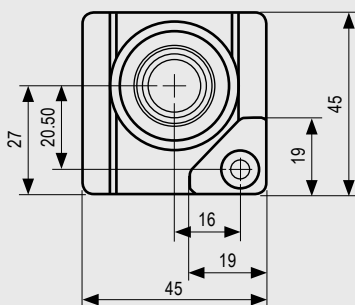
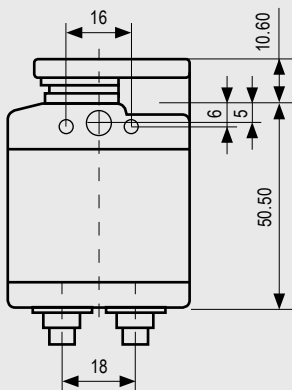

Dimensions in mm

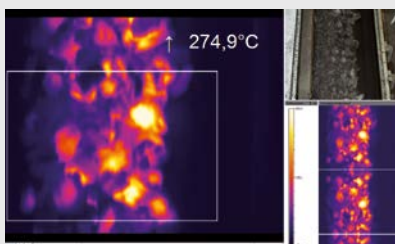

Monitoring of a carbon ribbon

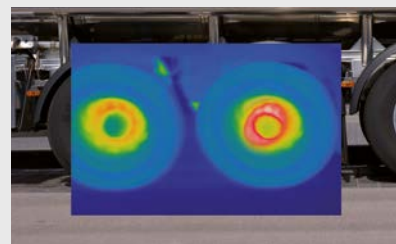

Measurement of the brake temperature in superimposed picture

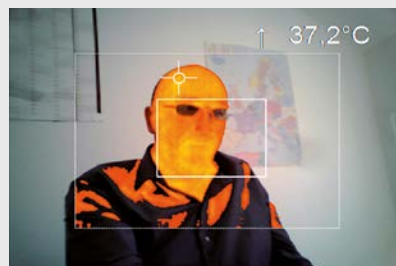

Cross-fade of a VIS image above 35 °C

The smallest camera in its class



- The smallest camera in its class (46 x 56 x 90 mm)
- Very good thermal sensitivity at 80 mK
- Thermal image recording in real time at up to 80 Hz
- Interchangeable lenses & industrial accessories
- Lightweight (320 g incl. lens)
- Detector with 382 x 288 pixels
- Includes license-free analysis software and full SDK

High-performance for a wide range of uses

The high-performance optris® PI 400 infrared camera has a wide range of uses in industry. For example, real time thermal image shots help to monitor processes and ensure the quality of manufactured products in the automotive field in particular, in the manufacture of plastics as well as in the semiconductor and photovoltaic industry.

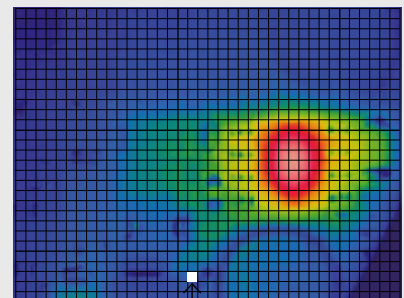
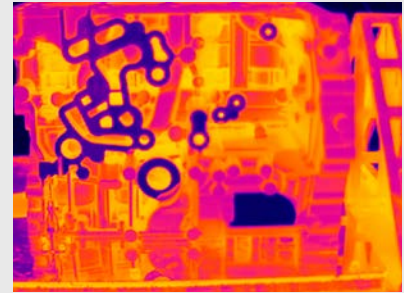

382 x 288 pixels | 10 x 10 pixels = 40 mm²

SMD chip as measurement object:
measurement field size: 240 mm x 180 mm,
pixel size: 0.63 mm

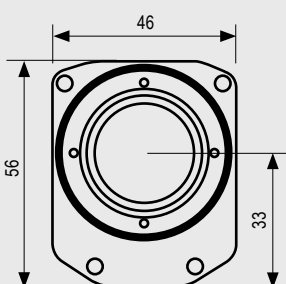
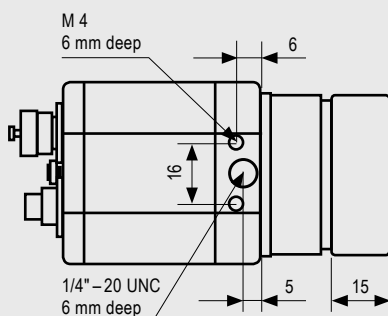
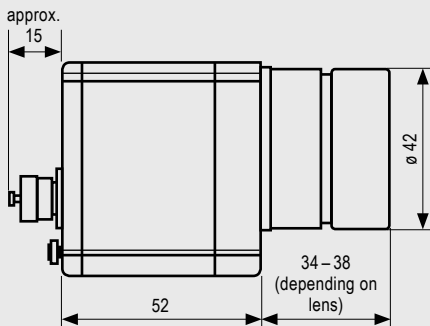

Dimensions in mm

80 Hz recordings with full pixel resolution

The display and recording of thermal images at full optical resolution can be done at high measurement speeds of 80 frames per second.

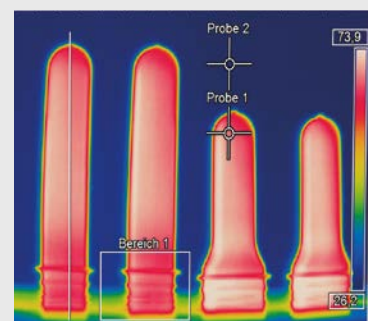

Thermal image shots of preforms in PET bottle production

optris® PI 450

INFRARED CAMERA

WITH VERY HIGH OPTICAL RESOLUTION

Detection of minimal temperature differences

- The smallest camera in its class (46 x 56 x 90 mm)
- Very good thermal sensitivity at 40 mK
- Thermal image recording in real time at up to 80 Hz
- Interchangeable lenses & industrial accessories
- Lightweight (320 g incl. lens)
- Detector with 382 x 288 pixels
- Usable at ambient temperatures of up to 70 °C without the need for additional cooling
- Includes license-free analysis software and full SDK



Highest temperature resolution of 40 mK

With an optical resolution of 40 mK, the optris® PI 450 is used for measuring the most subtle temperature differences, e.g. in the quality control of products or in preventive medicine.

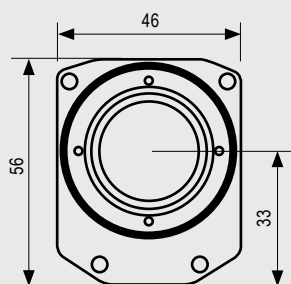
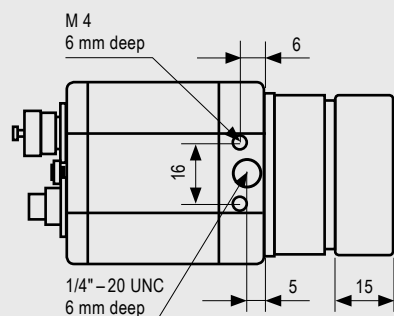
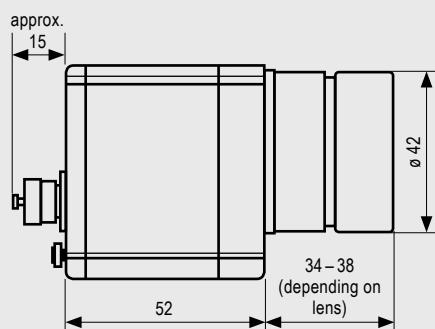
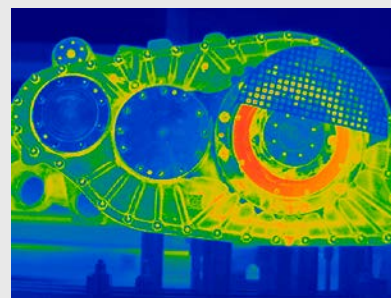

Dimensions in mm

Highest temperature resolution in the medical sector

The fine temperature resolution of the optris® PI 450 means that veins can even be seen under the skin.

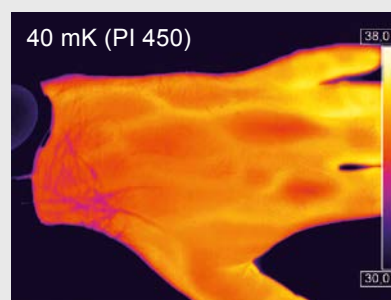
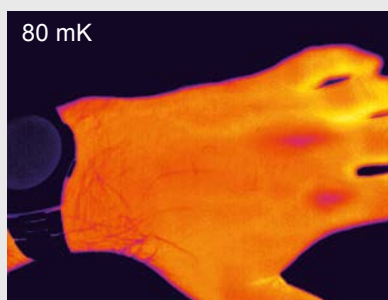

INFRARED CAMERA FOR ANECHOIC INFRARED SURFACE TEMPERATURE MEASUREMENTS ON GLASS

Thermography solutions for the glass industry

- Usable at ambient temperatures of up to 70 °C without the need for additional cooling
- With an integrated filter for the spectral range of 7.9 µm
- Compact size of 46 x 56 x 90 mm
- 80 Hz frame rate
- Includes license-free analysis software and full SDK



Exact temperature measurements on glass surfaces via line-scan camera function

The temperature of glass is best measured in the range of spectral absorption bands. For this purpose the optris® PI 450 G7 has an integrated 7.9 µm filter which enables an anechoic IR surface temperature measurement. Its compact size makes the optris® PI 450 G7 particularly suitable for use in confined spaces and for installation in industrial facilities. The infrared camera is fully operational at ambient temperatures of up to 70 °C without the need for cooling. With an imaging frequency of 80 Hz, glass products can be continuously tested, even in fast processing.

The line-scan camera function (linescan mode) of the PI Connect software enables the exact temperature measurement of panes of glass during transport on conveyor belts. This is a particularly important quality factor in tempering processes, e.g. in ESG and VSG.

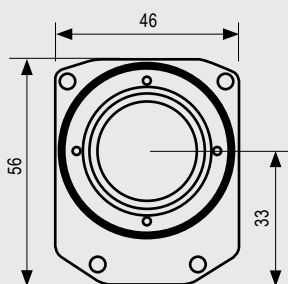
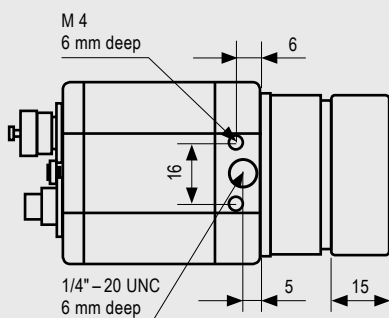
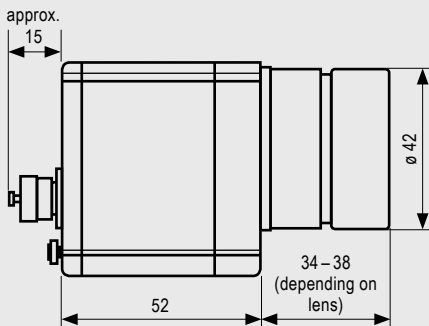
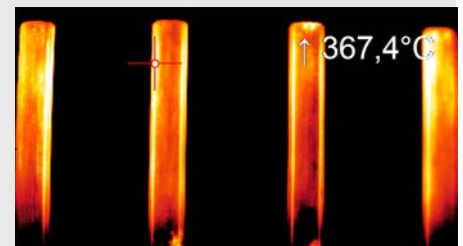
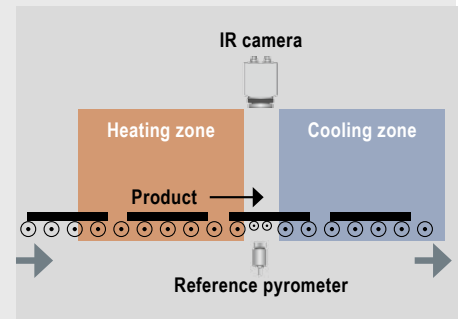
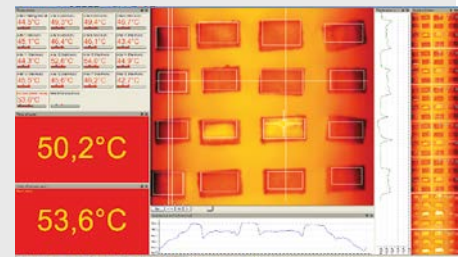

Dimensions in mm

optris® PI 640

THERMOGRAPHY
IN VGA RESOLUTION

The smallest VGA infrared measurement camera in the world

- 640 x 480 pixels
- Radiometric video recording at 32 Hz
- Compact size of 46 x 56 x 90 mm
- Lightweight (320 g incl. lens)
- Includes license-free analysis software and full SDK

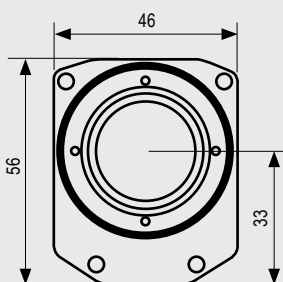
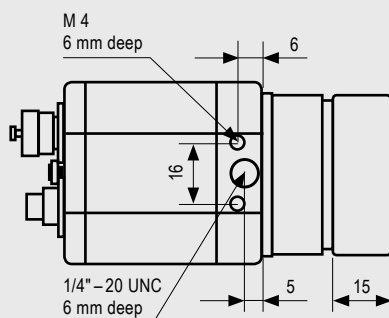
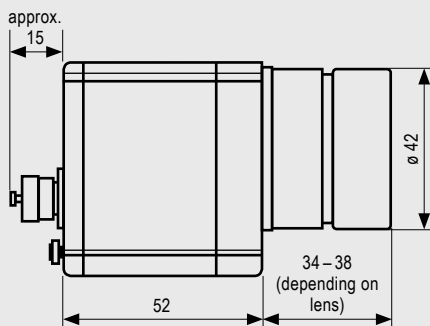
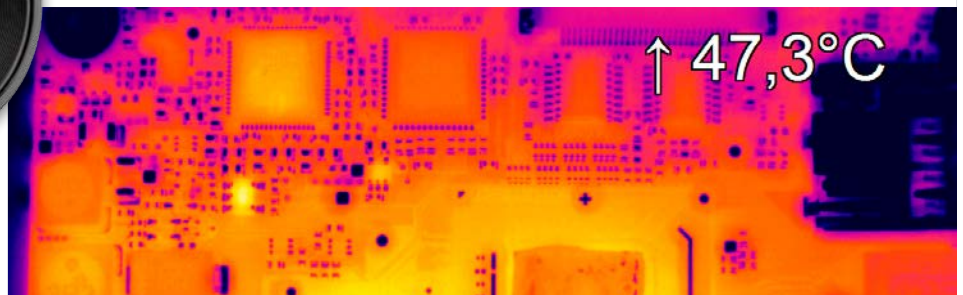
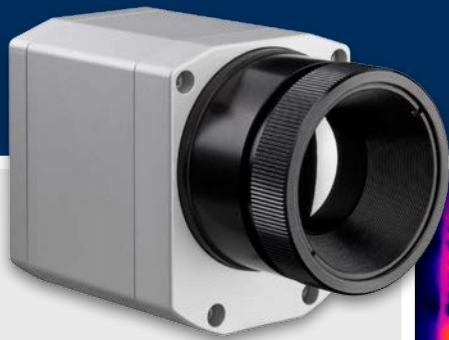

Dimensions in mm

Razor sharp infrared pictures and videos for process optimization

With a casing size of only 46 x 56 x 90 mm and a weight of 320 grams (incl. lens), the optris® PI 640 is among the most compact infrared cameras on the market.

The high-definition optris® PI 640 infrared camera is best used in applications where the very finest thermal details matter.

It significantly contributes to process optimization in both research and development and in industry.

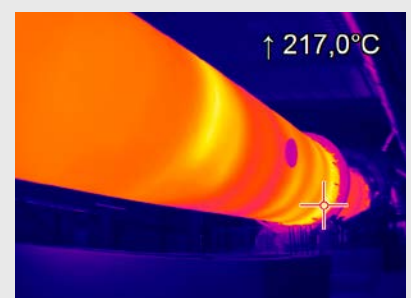
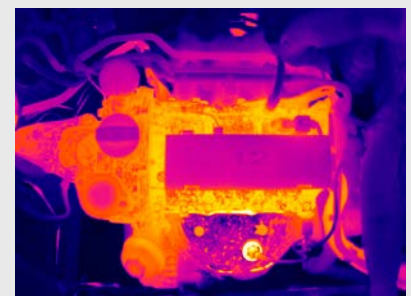
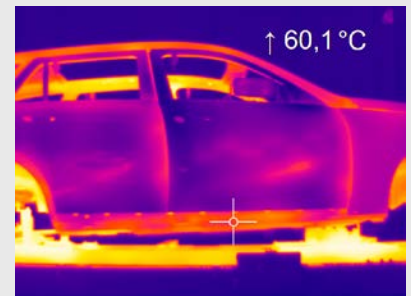

Ultra compact infrared camera for the metal industry

- Highly flexible CMOS detector with an optical resolution of up to 764 x 480 pixels
- Very large temperature measurement range (without sub-ranges) of 450 °C to 1800 °C
- Frame rates of up to 1 kHz for fast processes
- Real-time output of middle pixel at a set-up time of 1 ms
- Includes license-free analysis software and full SDK



Intelligent temperature measurement – innovative and quick

The new optris® PI 1M IR camera is specially suited for measuring the temperature of metals, as these exhibit a distinctly higher emissivity at the short measurement wavelength of 1µm than at measurements in the previously conventional wavelength range of 8–14 µm.

The advantage of temperature measurements with the new infrared camera lies in the large amount of information in an IR picture/IR video and the short reaction time of 1ms for the output of temperature information of freely selectable individual pixels.

The use of these new image sensors allows a large dynamic range for temperature measurement so that the previously necessary use of relatively many and narrowly defined sub-ranges is no longer required. Intelligent measuring with a pyrometer is now possible thanks to the two-dimensional temperature recording of the optris® PI 1M.

Thanks to the large measurement temperature range of 450–1800 °C, the optris® PI 1M IR camera satisfies practically all demands in the fields of metal production and processing.

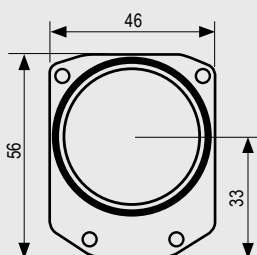
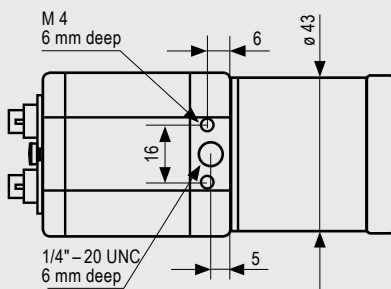
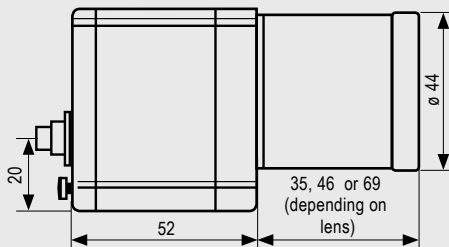
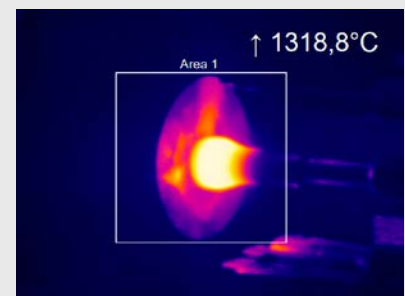
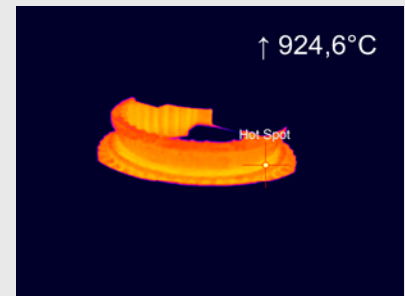
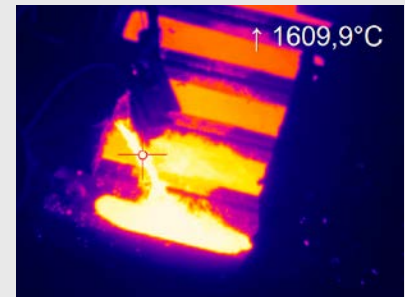

Dimensions in mm

Technical data

Compact infrared cameras for fast online applications, including line scanning



Basic model		PI 160	PI 200 / PI 230	PI 400 / PI 450
Type		IR	BI-SPECTRAL	IR
Detector		FPA, uncooled (25 µm x 25 µm)	FPA, uncooled (25 µm x 25 µm)	FPA, uncooled (25 µm x 25 µm)
Optical resolution		160 x 120 pixels	160 x 120 pixels	382 x 288 pixels
Spectral range		7.5–13 µm	7.5–13 µm	7.5–13 µm
Temperature ranges		–20 °C ... 100 °C, 0 °C ... 250 °C, 150 °C ... 900 °C, additional range: 200 °C ... 1500 °C (option)*	–20 °C ... 100 °C, 0 °C ... 250 °C, 150 °C ... 900 °C, additional range: 200 °C ... 1500 °C (option)*	–20 °C ... 100 °C, 0 °C ... 250 °C, 150 °C ... 900 °C, additional range: 200 °C ... 1500 °C (option for PI 400)
Frame rate		120 Hz	128 Hz***	80 Hz
Lenses (FOV)		23° x 17° / f = 10 mm or 6° x 5° / f = 35.5 mm or 41° x 31° / f = 5.7 mm or 72° x 52° / f = 3.3 mm	23° x 17°** / f = 10 mm or 6° x 5° / f = 35.5 mm or 41° x 31°** / f = 5.7 mm or 72° x 52° / f = 3.3 mm	38° x 29° / f = 15 mm or 62° x 49° / f = 8 mm or 13° x 10° / f = 41 mm or 80° x 58° / f = 7 mm
Thermal sensitivity (NETD)		0.08 K with 23° x 17° FOV / F = 0.8 0.3 K with 6° x 5° FOV / F = 1.6 0.1 K with 41° x 31° FOV and 72° x 52° FOV / F = 1	0.08 K with 23° x 17° FOV / F = 0.8 0.3 K with 6° x 5° FOV / F = 1.6 0.1 K with 41° x 31° FOV and 72° x 52° FOV / F = 1	PI 400: 0.08 K PI 450: 0.04 K mit 38° x 29° FOV / F = 0.8 PI 400: 0.08 K PI 450: 0.04 K mit 62° x 49° FOV / F = 0.8 PI 400: 0.1 K PI 450: 0.06 K mit 13° x 10° FOV / F = 1.0
Option for visual camera (only for BI-SPECTRAL camera)		–	Optical resolution: 640 x 480 pixels Frame rate: 32 Hz*** Lens (FOV): PI 200: 54° x 40°, PI 230: 30° x 23°	–
Accuracy		±2 °C or ±2 %, whichever is greater	±2 °C or ±2 %, whichever is greater	±2 °C or ±2 %, whichever is greater
PC interface		USB 2.0 / optional USB to GigE (PoE) conversion	USB 2.0 / optional USB to GigE (PoE) conversion	USB 2.0 / optional USB to GigE (PoE) conversion
Process interface (PIF)		Standard PIF: 0–10 V input, digital input (max. 24 V), 0–10 V output Industrial PIF (optional): 2 x 0–10 V inputs, digital input (max. 24 V), 3 x 0–10 V outputs, 3 x relays (0–30 V / 400 mA), fail-safe relays	0–10 V input, digital input (max. 24 V), 0–10 V output	0–10 V input, digital input (max. 24 V), 0–10 V output 2 x 0–10 V inputs, digital input (max. 24 V), 3 x 0–10 V outputs, 3 x relays (0–30 V / 400 mA), fail-safe relays
Ambient temperature (T _{Um})		0 °C ... 50 °C	0 °C ... 50 °C	PI 400: 0 °C ... 50 °C / PI 450: 0 °C ... 70 °C
Storage temperature		–40 °C ... 70 °C	–40 °C ... 70 °C	PI 400: –40 °C ... 70 °C PI 450: –40 °C ... 85 °C
Relative humidity		20–80 %, non-condensing	20–80 %, non-condensing	20–80 %, non-condensing
Enclosure (size/ rating)		45 mm x 45 mm x 62 mm / IP 67 (NEMA 4)	45 mm x 45 mm x 62 mm / IP 67 (NEMA 4)	46 mm x 56 mm x 90 mm / IP 67 (NEMA 4)
Weight		195 g, incl. lens	215 g, incl. lens	320 g, incl. lens
Shock/ vibration		Shock: IEC 60068-2-27 (25 g und 50 g) Vibration: IEC 60068-2-6 (sinus-shaped)/ IEC 60068-2-64 (broadband noise)	Shock: IEC 60068-2-27 (25 g und 50 g) Vibration: IEC 60068-2-6 (sinus-shaped)/ IEC 60068-2-64 (broadband noise)	Shock: IEC 60068-2-27 (25 g und 50 g) Vibration: IEC 60068-2-6 (sinus-shaped)/ IEC 60068-2-64 (broadband noise)
Tripod mount		1/4 - 20 UNC	1/4 - 20 UNC	1/4 - 20 UNC
Voltage supply		via USB	via USB	via USB
Scope of supply (standard)		<ul style="list-style-type: none"> • USB camera with 1 lens • USB cable (1 m) • Table-top tripod • PIF cable with connecting terminal strip (1 m) • optris® PI Connect software package • Aluminium case 	<ul style="list-style-type: none"> • USB camera with 1 lens and BI-SPECTRAL technology • USB cable (1 m) • Table-top tripod • Focus tool • PIF cable with connecting terminal strip (1 m) • optris® PI Connect software package • Aluminium case 	<ul style="list-style-type: none"> • USB camera with 1 lens • USB cable (1 m) • Table-top tripod • PIF cable with connecting terminal strip (1 m) • optris® PI Connect software package • Aluminium case (PI400) • Robust hard shell case (PI 450)

* The additional range is not available for 72° HFOV lenses

** For ideal combination of IR and VIS image, a 41° HFOV lens is recommended (PI 200). For the PI 230, a 23° lens is recommended

Optics calculator:
www.optris.com/optics-calculator



PI 450 G7	PI 640	PI 1M
IR	IR	IR
FPA, uncooled (25 µm x 25 µm)	FPA, uncooled (17 µm x 17 µm)	CMOS (15 µm x 15 µm)
382 x 288 pixels	640 x 480 pixels VGA	764 x 480 pixels @ 32 Hz 382 x 288 pixels @ 80 Hz (switchable to 27 Hz) 72 x 56 pixels @ 1 kHz
7.9 µm	7.5–13 µm	0.92–1.1 µm
200 ... 1500 °C	–20 ... 100 °C, 0 ... 250 °C, 150 ... 900 °C	450 ... 1800 °C (27 Hz mode) 500 ... 1800 °C (80 Hz and 32 Hz mode) 600 ... 1800 °C (1 kHz mode)
80 Hz / switchable to 27 Hz	32 Hz	Up to 1 kHz
38° x 29° / f = 15 mm or 62° x 49° / f = 8 mm or 80° x 58° / f = 7 mm	33° x 25° / f = 19 mm or 15° x 11° / f = 41.5 mm or 60° x 45° / f = 10 mm or 90° x 66° / f = 7 mm	FOV@764 x 480 px: 87° x 62° (f = 6 mm) 51° x 33° (f = 12 mm) 39° x 25° (f = 16 mm) 26° x 16° (f = 25 mm) 13° x 8° (f = 50 mm) 9° x 5° (f = 75 mm) FOV@382 x 288 px: 51° x 40° (f = 6 mm) 27° x 20° (f = 12 mm) 20° x 15° (f = 16 mm) 13° x 10° (f = 25 mm) 7° x 5° (f = 50 mm) 4° x 3° (f = 75 mm)
130 mK	75 mK	< 1 K (700 °C) < 2 K (1000 °C)
–	–	–
±2 °C or ±2 %, whichever is greater	±2 °C or ±2 %, whichever is greater	±2% of reading (object temperature <1500 °C)
USB 2.0 / optional USB to GigE (PoE) conversion	USB 2.0 / optional USB to GigE (PoE) conversion	USB 2.0 / optional USB to GigE (PoE) conversion
0–10 V input, digital input (max. 24 V), 0–10 V output	0–10 V input, digital input (max. 24 V), 0–10 V output	0–10 V input, digital input (max. 24 V), 0–10 V output
2x 0–10 V inputs, digital input (max. 24 V), 3x 0–10 V outputs, 3x relays (0–30 V / 400 mA), fail-safe relays	2x 0–10 V inputs, digital input (max. 24 V), 3x 0–10 V outputs, 3x relays (0–30 V / 400 mA), fail-safe relays	2x 0–10 V inputs, digital input (max. 24 V), 3x 0–10 V outputs, 3x relays (0–30 V / 400 mA), fail-safe relays
0 ... 70 °C	0 ... 50 °C	0 ... 50 °C
–40 ... 85 °C	–40 ... 70 °C	–40 ... 70 °C
20–80 %, non-condensing	20–80 %, non-condensing	20–80 %, non-condensing
46 mm x 56 mm x 90 mm / IP 67 (NEMA 4)	46 mm x 56 mm x 90 mm / IP 67 (NEMA 4)	46 mm x 56 mm x 90 mm / IP 67 (NEMA 4) ¹⁾
320 g, incl. lens	320 g, incl. lens	320 g, incl. lens
Shock: IEC 60068-2-27 (25 g und 50 g) Vibration: IEC 60068-2-6 (sinus-shaped)/ IEC 60068-2-64 (broadband noise)	Shock: IEC 60068-2-27 (25 g und 50 g) Vibration: IEC 60068-2-6 (sinus-shaped)/ IEC 60068-2-64 (broadband noise)	Shock: IEC 60068-2-27 (25 g und 50 g) Vibration: IEC 60068-2-6 (sinus-shaped)/ IEC 60068-2-64 (broadband noise)
1/4-20 UNC	1/4-20 UNC	1/4-20 UNC
via USB	via USB	via USB
<ul style="list-style-type: none"> • USB camera with 1 lens • USB cable (1 m) • Table-top tripod • PIF cable with connecting terminal strip (1 m) • optris® PI Connect software package • Robust hard shell case 	<ul style="list-style-type: none"> • USB camera with 1 lens • USB cable (1 m) • Table-top tripod • PIF cable with connecting terminal strip (1 m) • optris® PI Connect software package • Robust hard shell case 	<ul style="list-style-type: none"> • USB camera with 1 lens • Lens cap incl. protective window • USB cable (1 m) • Table-top tripod • PIF cable with connecting terminal strip (1 m) • optris® PI Connect software package • Aluminium case • Optional: CoolingJacket, high temp. cable

*** The following options can be set:

- Option 1 (IR with 96 Hz at 160 x 120 px; VIS with 32 Hz at 640 x 480 px)
- Option 2 (IR mit 128 Hz at 160 x 120 px; VIS with 32 Hz at 596 x 447 px)

¹⁾ Only applies when lens protection tube is used

optris® PI LightWeight

EXTRA LIGHT CAMERA WITH MINI PC

The infrared camera for flight applications

- Complete radiometric IR inspection with 382 x 288 pixels at 12 ms per picture
- 380 g design (two piece) with minimized camera head weight
- Simultaneous 20 Hz video signal generation parallel to 35 Hz radiometric recording on the module
- Flexible PI Connect software for data recording and analysis
- GigE connection for post flight video downloading and software customization via "remote desktop"
- Supports HD video camera; read-out over additional USB connection

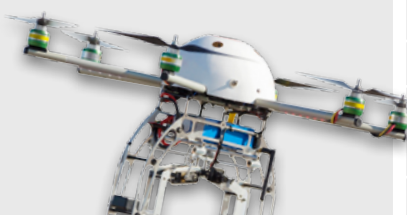

General specifications Lightweight PC (PI NetBox)

Operating temperature	0 ... 50 °C
Storage temperature	-20 ... 50 °C
Relative humidity	10 ... 95 %, non-condensing
Dimensions	112 x 58 x 54 mm
Weight (NetBox+PI)	380 g
Vibration	IEC-2-6: 3G, 11 – 200 Hz, every axis
Shock	IEC-2-27: 50G, 11 ms, every axis
Operating system	Windows XP Professional

Electrical specifications Lightweight PC (PI NetBox)

Voltage supply	8 ... 48 V DC or Power over Ethernet (PoE/ 1000 BASE-T)
Power consumption	9.5 W (+ additional 2.5W for PI camera)
Cooling	Active (integrated fan)
Module	COM Express® mini embedded board
Processor	Intel® Atom™ Z530/ 1.6 GHz
Hard drive	4 GB SSD
RAM	1 GB (DDR2, 533 MHz)
Connections	2x USB 2.0, 1x Mini-USB 2.0 (slave mode), TV _{out} , Ethernet (Gigabit Ethernet)
Memory card slots	micro SDHC card (up to 32 GB)
Additional features	Remote control recording start and stop via switch on camera, 6 status LEDs

General specifications optris® PI camera head

Measurement range	-20 ... 900 °C
Spectral range	7.5 – 13 µm
Accuracy	± 2 % or ± 2 °C
Lens	62° FOV (38° FOV optional)
Optical Resolution	382 x 288 pixels
Dimensions	46 x 56 x 90 mm

Standalone solution in thermal monitoring



- Miniature PC for PI 160/ 4xx standalone operation or for cable extension
- Supports 120 Hz (PI 160) through to 70 Hz (PI 4xx) framerate
- Integrated watchdog function
- Installation of additional user software possible
- Processor: Intel® Atom™ z530 @ 1.6 GHz, 4 GB SSD, 1 GB RAM
- Status LEDs
- Connections: 3x USB 2.0, 1x mini USB in slave mode, VGA/ Video, Gigabit Ethernet, micro SDHC card (up to 32 GB)
- Operating system: Windows XP Professional
- Wide supply voltage range: 8 – 48 V DC or Power over Ethernet (PoE)
- Low power consumption (max. 9.5 W)
- Up to 20 m USB high temperature USB cable, extendable to up to 100 m ethernet cable (PoE)

General specifications

Operating temperature	0–50 °C
Storage temperature	–20 ... 75 °C
Relative humidity	10 ... 95 %, non-condensing
Material (casing)	anodized aluminium
Dimensions	113 x 57 x 39 mm
Weight	280 g
Vibration	IEC-2-6: 3G, 11–200 Hz, every axis
Shock	IEC-2-27: 50G, 11 ms, every axis
Operating system	Windows XP Professional

Electrical specifications

Voltage supply	8 ... 48 V DC or Power over Ethernet (PoE/ 1000 BASE-T)
Power consumption	9.5 W (+ additional 2.5W for PI camera)
Cooling	Passive (active with integrated fan for ambient temperatures over 50 °C)
Module	COM Express® mini embedded board
Processor	Intel® Atom™ Z530/ 1.6 GHz
Hard drive	4 GB SSD
RAM	1 GB (DDR2, 533 MHz)
Connections	3x USB 2.0, 1x Mini-USB 2.0 (slave mode), VGA/TV _{out} , Ethernet (Gigabit Ethernet)
Memory card slots	micro SDHC card (up to 32 GB)
Additional features	6 status LEDs (L1-L6)

Ethernet communication over network

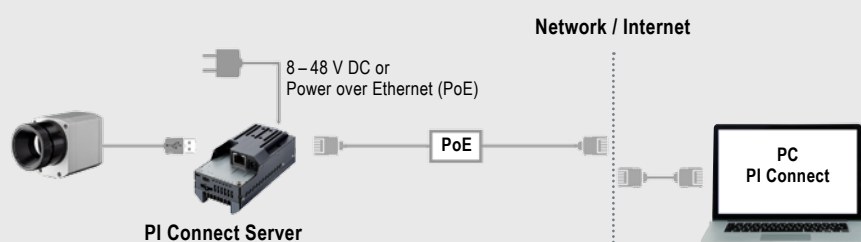

optris® USB Server Gigabit

SIMPLE CABLE EXTENSION

Simple cable extension for the optris® PI series

- Fully compatible with USB 2.0, Data transfer rate 1.5 / 12 / 480 mbps, USB transfer modes: control, bulk, interrupt, isochronous
- Network connection via Gigabit Ethernet
- For all models in the optris® PI series
- Full TCP/IP support incl. routing and DNS
- Two independent USB connections
- Power via PoE or external voltage supply at 24 – 48 V DC
- Galvanic isolation 500 V_{RMS} (network connection)
- Remote configuration via web-based management
- Certified technology from Wiesemann & Theis



Technical data

USB connections	2 x USB A Port
USB speed	480 Mbit/s
Network	10/100/1000 BaseT (max. 1000 Mbit/s)
Power supply	Power over Ethernet (PoE) class 3 (6.49 – 12.95 W) or via screw terminal DC 24 V ... 48 V (+/-10 %)
Power consumption	External power supply (24 V DC) without USB devices: typ. 120 m A External power supply (24 V DC) with 2 USB devices each 2.5 W : typ. 420 mA
Ambient temperature	Storage: – 40 ... 85 °C In operation, individually assembled: 0 ... 50 °C
Permissible relative humidity	0 – 95 % (non-condensing)
Casing	Compact plastic casing for DIN rail mount, 105 x 75 x 22 mm
Weight	200 g
Contents	<ul style="list-style-type: none"> • 1 x USB-Server Gigabit • 24 V DC wall plug transformer • Quick guide* <p>*included on PI Connect CD or Compact Connect CD: – USB-Redirector – WuTility Management Tool – Operating instructions (DE / EN)</p>

Protocols

USB protocols	USB 1.0 / 1.1 / 2.0 Control / Bulk / Interrupt / Isochronous
Protocols for direct network connection	TCP/IP: Socket Auxiliary protocols: ARP, DHCP, HTTP, PING Inventory keeping, group management

Connection options

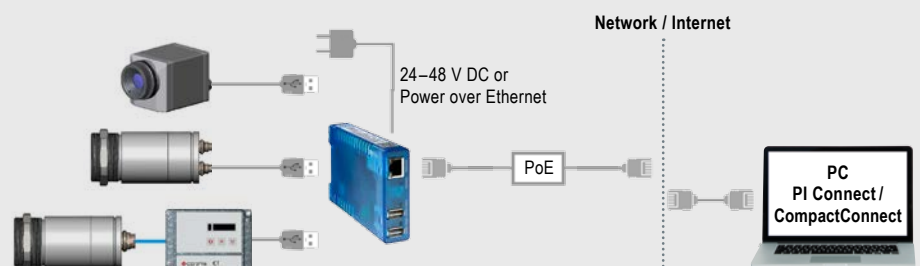

UNIVERSAL PROTECTIVE HOUSING FOR COOLING UP TO 315 °C

Universal protection for the optris® PI series under harsh industrial environments

- Operation at ambient temperatures of up to 315 °C
- Also available as protective casing with cooling function up to 180° C
- Air/Water cooling with integrated air purging and optional protective windows
- Modular design for easy fitting of different devices and lenses
- Trouble-free, on the spot sensor removal via quick-release chassis
- Integration of additional components like PI NetBox, USB server gigabit and Industrial Process Interface (PIF) in the extended version



Technical data	CoolingJacket	CoolingJacket Advanced Standard	CoolingJacket Advanced Extended
Protective rating	IP 65	IP 65	IP 65
Ambient temperature	up to 180 °C	up to 315 °C ¹⁾	up to 315 °C ¹⁾
Relative humidity	10 ... 95 %, non-condensing	10 ... 95 %, non-condensing	10 ... 95 %, non-condensing
Material (casing)	V2A	V2A	V2A
Dimensions	237 mm x 117 mm x 138 mm	271 mm x 166 mm x 182 mm	426 mm x 166 mm x 182 mm
Weight	4.5 kg	5.7 kg	7.8 kg
Air purge collar	G1/4" internal thread G3/8" external thread	G1/4" internal thread G3/8" external thread	G1/4" internal thread G3/8" external thread
Cooling water fittings	G1/4" internal thread G3/8" external thread	G1/4" internal thread G3/8" external thread	G1/4" internal thread G3/8" external thread
Cooling water pressure	max. 15 bar (217 psi)	max. 15 bar (217 psi)	max. 15 bar (217 psi)
Contents	<ul style="list-style-type: none"> • CoolingJacket, consisting of casing and chassis 	<ul style="list-style-type: none"> • CoolingJacket Advanced, consisting of casing with mounting brackets, chassis and focusing unit or front attachment • Assembly instructions 	<ul style="list-style-type: none"> • CoolingJacket Advanced, consisting of casing with mounting brackets, chassis and focusing unit or front attachment • Mounting accessories for <ul style="list-style-type: none"> – PI Netbox or USB Server Gigabit – Industrial PIF • Assembly instructions

¹⁾ Cable for up to 250 °C ambient temperature as well as cable cooling for up to 315 °C available.

Dimensions in mm

CoolingJacket Advanced – Extended version

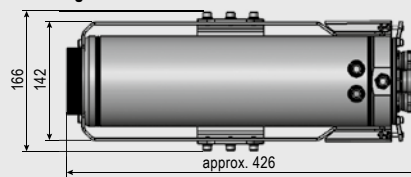

CoolingJacket Advanced – Standard version

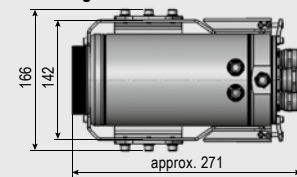

CoolingJacket

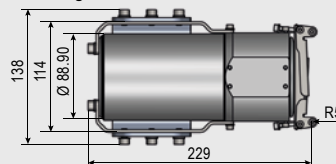

optris® Industrial Process Interface

WITH FAIL-SAFE MONITORING

Camera and process control for use in an industrial environment

- Industrial Process Interface with 3 analog / alarm outputs, 2 analog inputs, 1 digital input, 3 alarm relays
- 500 V AC_{RMS} isolation voltage between camera and process
- Separate fail-safe relay output
- The PI hardware with all cable connections and the PI Connect software are permanently monitored during operation



General specifications

Protective rating	IP65 (NEMA-4)
Ambient temperature	-30 °C ... 85 °C
Storage temperature	-30 °C ... 85 °C
Humidity	10–95 %
Vibrational stability	IEC 60068-2-6 (non condensing)/ IEC 60068-2-64 (broadband noise)
Shock stability	IEC 60068-2-27 (25 g and 50 g)
Weight	610 g (with 5 m cable)
Cable lengths	5 m HT cable (standard), optional 10 m and 20 m

Electrical specifications

Voltage supply	5–24 V DC
LED indicators	2 green LEDs for voltage and fail safe / 3 red LEDs for alarm relay status
Isolation	500 V AC _{RMS} between PI camera und process
Outputs	3 analog / alarm outputs 3 alarm relays ¹⁾
Inputs	2 analog inputs 1 digital input
Ranges	0–10 V (for AO 1–3) ²⁾ 0–30 V / 400 mA (for alarm relays DO1–3) 0–10 V (for AI 1–2) 24 V (for DI)

Programmable functions

Analog inputs	<ul style="list-style-type: none"> • Emissivity setting • Ambient temperature compensation • Reference temperature • Uncommitted value • Flag control • Triggered snapshots, triggered recordings, triggered line scan camera
Digital input	<ul style="list-style-type: none"> • Flag control • Triggered snapshots, triggered recordings, triggered line scan camera
Analog outputs	<ul style="list-style-type: none"> • Main measurement range • Measurement range • Internal temperature • Flag status • Alarm • Frame sync. • Fail-Safe • External communication

¹⁾ active when AO1, 2 or 3 is / are programmed as alarm output

²⁾ dependent on supply voltage

Example of fail-safe monitoring of the PI camera with connected PLC

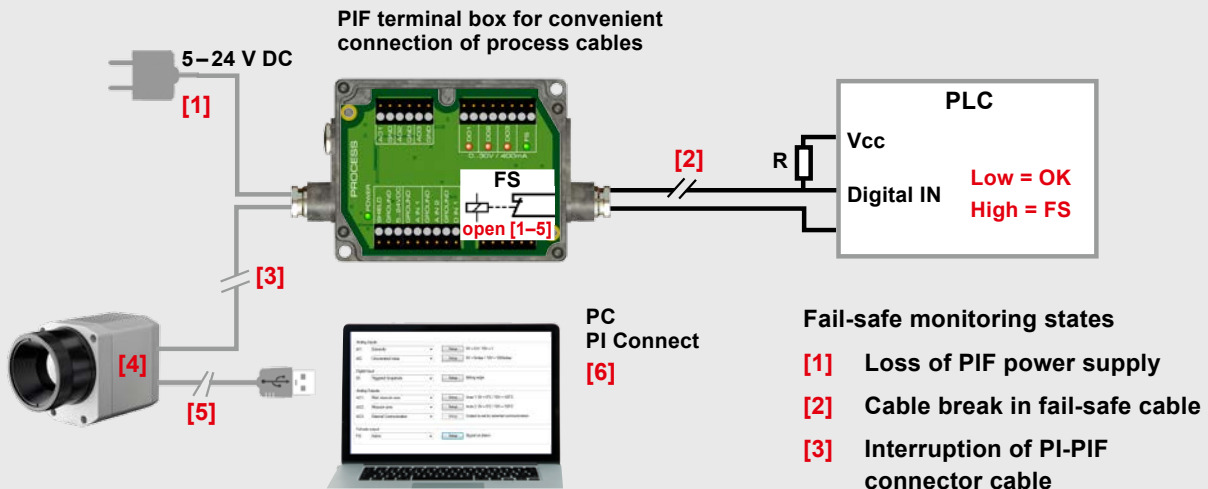

Fail-safe monitoring states

- [1] Loss of PIF power supply
- [2] Cable break in fail-safe cable
- [3] Interruption of PI-PIF connector cable
- [4] PI camera malfunction
- [5] Loss of PI power supply/ Interruption of USB cable
- [6] Loss of PI power supply/ Interruption of USB cable

Fail-Safe-Status:

Normal: Relais closed LED on
 Alarm: Relais open LED off

Overview of programmable functions

1 Comprehensive IR camera software

- No additional costs
- No licensing restrictions
- Modern software with intuitive user interface
- Remote control of camera via software
- Display of numerous images in different windows
- Compatible with Windows 7 and 8 as well as Linux (ubuntu)
- Includes license-free analysis software and full SDK



3 High degree of individualization for customer-specific imaging

- Various layout options for individual customization (window arrangement, toolbar)
- Temperature display in °C or °F
- Various language options including translate function
- Choice of individual measurement parameters tailored to the respective application
- Editing of the thermal image (flip, rotate)
- Individual start options (full screen, hidden etc.)

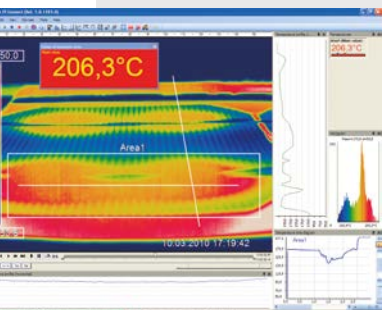

5 Video recording and snapshot function (IR or BI-SPECTRAL)

- Recording of video sequences and individual images for later analysis or documentation
- BI-SPECTRAL video analysis (IR and VIS) to highlight critical temperatures
- Adjustable frame rate to reduce data volume
- Display of snapshot process for direct analysis

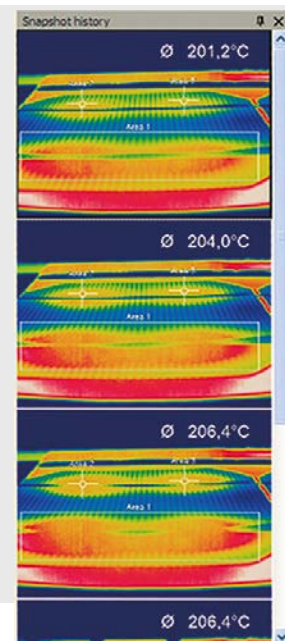

2 Detailed online and offline data analysis

- Real time temperature information in main window, as digital display or graphic display
- Detailed analysis with the help of measurement fields, automatic hotspot and coldspot search
- Logical linking of temperature information (measurement field discrepancy, image subtraction)
- Slow-motion replay of radiometric datasets and analysis even without connected camera
- Editing of sequences, e.g. cut and save individual images
- Various colour palettes to highlight thermal contrasts

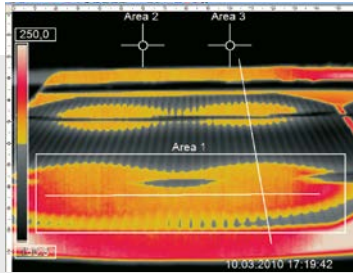

4 Automatic process control and quality control

- Individual setting of alarm thresholds depending on the process
- BI-SPECTRAL monitoring mode (IR and VIS) for easy orientation at the measuring point
- Definition of visual or acoustic alarms and analog data output
- Analog and digital signal input (parameter)
- External communication of software via Comports, DLL
- Adjustment of thermal image via reference values

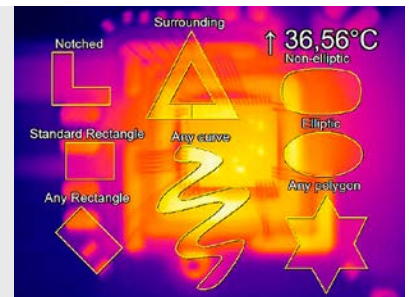

6 Temperature data analysis and documentation

- Triggered data gathering
- Radiometric video sequences (*.ravi)
- Radiometric snapshots (*.tiff)
- Text files including comprehensive temperature information for analysis in Excel (*.csv, *.dat)
- Files with colour information for standard programs like Photoshop or Windows Media Player (*.avi, *.tiff)
- Data transfer in real time to other software programs via DLL or COM-Port interfaces

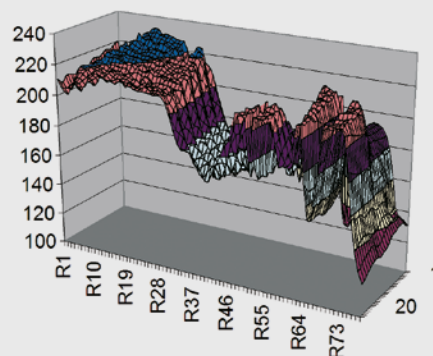

For the measurement of moving objects

The optris® PI Connect software is equipped with a line scan camera function. The line scanner is primarily used for processes involving moving measurement objects, like rotary kiln measurements or large quantities on conveyor belts (batch process).

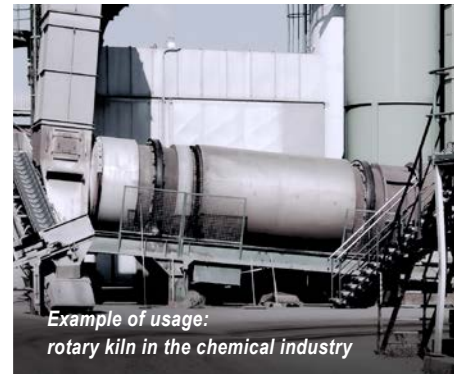

The advantages

Simple monitoring of processes with limited visual access

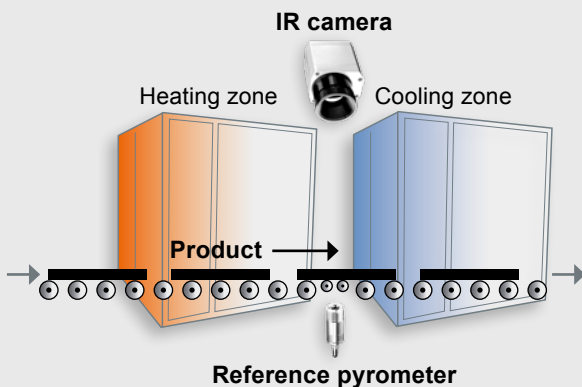

Only 3 steps to initialize the function

Step 1

Activation of the line scan camera function and definition of the position of the lines in the thermal image. For this the camera itself serves as an orientation aid.

Step 2

Configuration of line scan function, e.g. number of lines displayed or set trigger for automatic saving of images.

Step 3

Definition of individual layouts, e.g. display of saved images in the snapshot process.

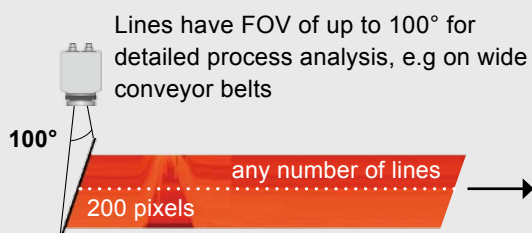

Up to 128 Hz data recording of unlimited lines which in turn produce a thermal image of any given resolution

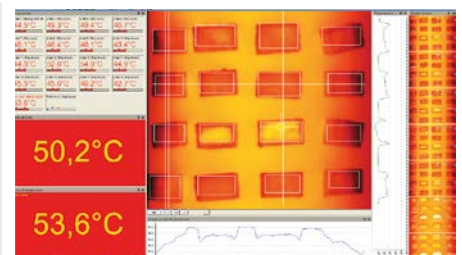

Precise measuring at various distances

A choice of lenses makes it possible for you to precisely measure objects at various distances, from close and standard distances right up to large distances.

With infrared cameras there are various parameters which display the relationship between the distance from the measuring object and the size of the pixel on the object plane. In choosing the correct lens, the following should be taken into account:

HFOV

Horizontal expansion of the total measuring field on the object plane.

VFOV

Vertical expansion of the total measuring field on the object plane

IFOV

Size of individual pixels on the object plane

DFOV

Diagonal expansion of the total measuring field on the object plane

MFOV

Recommended, smallest measuring object size of 3 x 3 pixels

Measuring field of optris® PI infrared camera using a 23° x 17° lens

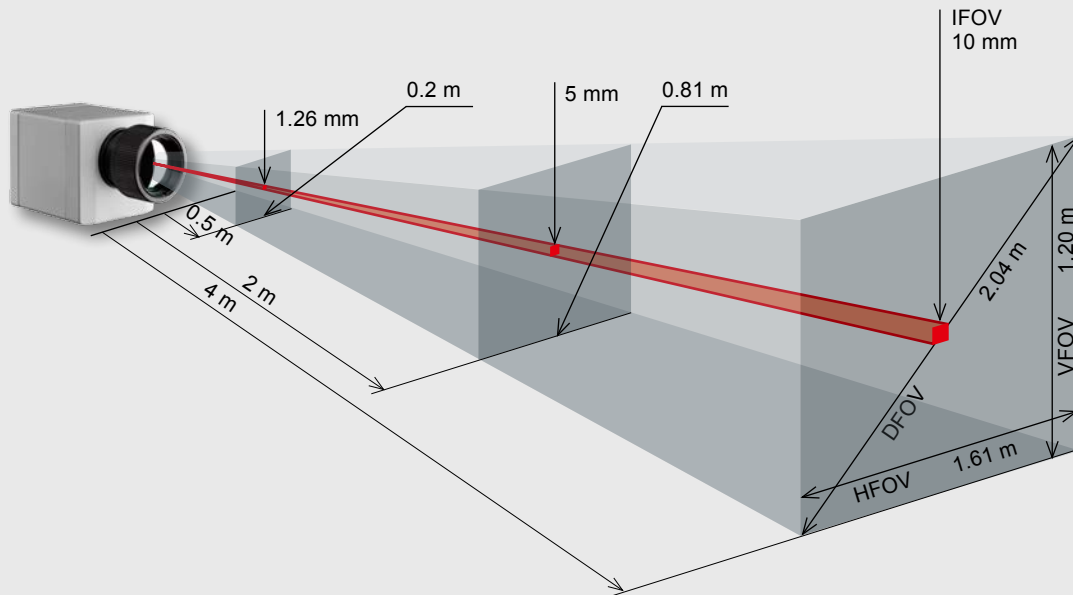

Optics calculator

Measurement field sizes for any given distance can be calculated online at www.optris.com/optics-calculator



Optical data

OPTICS

PI 160 / 200 160 x 120 px	Focal length [mm]	Angle	Minimum measurement distance*	Distance to measurement object [m]												
					0.02	0.1	0.2	0.3	0.5	1	2	4	6	10	30	100
O23 Standard lens	10	23°	0.2 m	HFOV [m]	0.008	0.040	0.08	0.12	0.20	0.40	0.81	1.61	2.42	4.0	12.1	40.3
		17°		VFOV [m]	0.006	0.030	0.06	0.09	0.15	0.30	0.60	1.20	1.79	3.0	9.0	29.9
		29°		DFOV [m]	0.010	0.051	0.10	0.15	0.26	0.51	1.02	2.04	3.06	5.1	15.3	51.1
		2.52 mrad		I FOV [mm]	0.1	0.3	0.5	0.8	1.3	2.5	5.0	10.1	15.1	25.2	75.6	252.0
O6 Telephoto lens	35.5	6°	0.5 m	HFOV [m]					0.06	0.11	0.23	0.45	0.68	1.1	3.4	11.3
		5°		VFOV [m]					0.04	0.08	0.17	0.34	0.50	0.8	2.5	8.4
		8°		DFOV [m]					0.07	0.14	0.28	0.56	0.84	1.4	4.2	14.1
		0.71 mrad		I FOV [mm]					0.4	0.7	1.4	2.8	4.2	7.1	21.2	70.5
O48 Wide angle lens	5.7	41°	0.2 m	HFOV [m]	0.015	0.076	0.15	0.23	0.38	0.76	1.51	3.02	4.53	7.6	22.7	75.6
		31°		VFOV [m]	0.011	0.055	0.11	0.16	0.27	0.55	1.09	2.19	3.28	5.5	16.4	54.7
		52°		DFOV [m]	0.019	0.097	0.19	0.29	0.49	0.97	1.95	3.90	5.85	9.7	29.2	97.5
		4.72 mrad		I FOV [mm]	0.1	0.5	0.9	1.4	2.4	4.7	9.5	18.9	28.3	47.2	141.7	472.3
O72 Wide angle lens	3.3	72°	0.2 m	HFOV [m]	0.029	0.145	0.29	0.44	0.73	1.45	2.91	5.81	8.72	14.5	43.6	145.3
		52°		VFOV [m]	0.020	0.098	0.20	0.29	0.49	0.98	1.95	3.90	5.85	9.8	29.3	97.5
		95°		DFOV [m]	0.043	0.217	0.43	0.65	1.09	2.17	4.34	8.68	13.02	21.7	65.1	217.0
		9.08 mrad		I FOV [mm]	0.2	0.9	1.8	2.7	4.5	9.1	18.2	36.3	54.5	90.8	272.5	908.2

PI 400 / 450 382 x 288 px	Focal length [mm]	Angle	Minimum measurement distance*	Distance to measurement object [m]												
					0.02	0.1	0.2	0.3	0.5	1	2	4	6	10	30	100
O38 Standard lens	15	38°	0.2 m	HFOV [m]	0.014	0.069	0.14	0.21	0.35	0.69	1.39	2.77	4.16	6.9	20.8	69.3
		29°		VFOV [m]	0.010	0.051	0.10	0.15	0.25	0.51	1.02	2.03	3.05	5.1	15.2	50.8
		49°		DFOV [m]	0.018	0.092	0.18	0.28	0.46	0.92	1.84	3.68	5.52	9.2	27.6	92.0
		1.81 mrad		I FOV [mm]	0.1	0.2	0.4	0.5	0.9	1.8	3.6	7.3	10.9	18.1	54.4	181.3
O13 Telephoto lens	41	13°	0.5 m	HFOV [m]					0.12	0.23	0.47	0.94	1.40	2.3	7.0	23.4
		10°		VFOV [m]					0.09	0.17	0.35	0.70	1.05	1.7	5.2	17.5
		17°		DFOV [m]					0.15	0.29	0.58	1.17	1.75	2.9	8.8	29.2
		0.61 mrad		I FOV [mm]					0.3	0.6	1.2	2.5	3.7	6.1	18.4	61.2
O62 Wide angle lens	8	62°	0.5 m	HFOV [m]	0.024	0.120	0.24	0.36	0.60	1.20	2.40	4.80	7.20	12.0	36.0	119.9
		49°		VFOV [m]	0.018	0.090	0.18	0.27	0.45	0.90	1.80	3.60	5.41	9.0	27.0	90.1
		74°		DFOV [m]	0.030	0.150	0.30	0.45	0.75	1.50	3.00	6.00	8.99	15.0	45.0	149.9
		3.14 mrad		I FOV [mm]	0.1	0.3	0.6	0.9	1.6	3.1	6.3	12.6	18.8	31.4	94.2	314.0
O80 Wide angle lens	7,33	80°	0.2 m	HFOV [m]		0.167	0.33	0.50	0.8	1.7	3.3	6.7	10.0	16.7	50.1	167.0
		58°		VFOV [m]		0.111	0.22	0.33	0.55	1.1	2.2	4.4	6.6	11.1	33.2	110.7
		104°		DFOV [m]		0.255	0.51	0.8	1.3	2.5	5.1	10.2	15.3	25.5	76.4	254.5
		3.41 mrad		I FOV [mm]		0.3	0.7	1.0	1.7	3.4	6.8	13.6	20.5	34.1	102.3	341.1

Table with examples showing which measurement field sizes and pixel sizes will be reached at which distance. For optimal configuration of the camera there are various lenses available. Wide angle lenses have radial distortion due to the angle of their aperture. The PI Connect software has an algorithm which corrects this distortion.

* Please note: The measurement accuracy of the camera may lie outside of the specifications for distances below the defined minimum measurement distance.

PI 640 640 x 480 px	Focal length [mm]	Angle	Minimum measurement distance*	Distance to measurement object [m]											
					0.1	0.2	0.3	0.5	1	2	4	6	10	30	100
O33 Standard lens	18.7	33°	0.2 m	HFOV [m]	0.059	0.12	0.18	0.30	0.59	1.19	2.37	3.56	5.9	17.8	59.3
		25°		VFOV [m]	0.044	0.09	0.13	0.22	0.44	0.88	1.77	2.65	4.4	13.2	44.1
		41°		DFOV [m]	0.075	0.15	0.22	0.37	0.75	1.50	3.00	4.50	7.5	22.5	74.9
		0.909 mrad		IFOV [mm]	0.1	0.2	0.3	0.5	0.9	1.8	3.6	5.5	9.1	27.3	90.9
O15 Tele lens	41,5	15°	0,4 m	HFOV [m]	0.03	0.05	0.08	0.13	0.26	0.52	1.05	1.57	2.6	7.9	26.2
		11°		VFOV [m]	0.02	0.04	0.06	0.10	0.20	0.39	0.79	1.18	2.0	5.9	19.7
		19°		DFOV [m]	0.03	0.07	0.10	0.16	0.33	0.66	1.31	1.97	3.3	9.8	32.8
		0,41 mrad		IFOV [mm]	0.0	0.1	0.1	0.2	0.4	0.8	1.6	2.5	4.1	12.3	41.0
O60 Wide angle lens	10.5	60°	0.2 m	HFOV [m]	0.115	0.23	0.35	0.58	1.15	2.31	4.62	6.92	11.5	34.6	115.4
		45°		VFOV [m]	0.082	0.16	0.25	0.41	0.82	1.65	3.30	4.95	8.2	24.7	82.4
		75°		DFOV [m]	0.155	0.31	0.46	0.77	1.55	3.09	6.18	9.27	15.5	46.4	154.6
		1.62 mrad		IFOV [mm]	0.2	0.3	0.5	0.8	1.6	3.2	6.5	9.7	16.2	48.6	161.9
O90 Super wide angle lens	7.33	90°	0.2 m	HFOV [m]	0.203	0.41	0.61	1.01	2.03	4.06	8.11	12.17	20.3	60.8	202.8
		66°		VFOV [m]	0.130	0.26	0.39	0.65	1.30	2.60	5.20	7.79	13.0	39.0	129.9
		120°		DFOV [m]	0.356	0.71	1.07	1.78	3.56	7.12	14.24	21.37	35.6	106.8	356.1
		2.32 mrad		IFOV [mm]	0.2	0.5	0.7	1.2	2.3	4.6	9.3	13.9	23.2	69.6	231.9

PI 1M 382 x 288 px	Focal length [mm]	Angle	Minimum measurement distance*	Distance to measurement object [m]											
					0.1	0.2	0.3	0.5	1	2	4	6	10	30	100
OF6	6	51°	0.5 m	HFOV [m]				0.96	1.91	3.82	5.73	9.6	28.7	95.5	95.5
		40°		VFOV [m]				0.72	1.44	2.88	4.32	7.2	21.6	72.0	72.0
		64°		DFOV [m]				1.25	2.51	5.02	7.53	12.5	37.6	125.5	125.5
		2.50 mrad		IFOV [mm]				2.5	5.0	10.0	15.0	25.0	75.0	250.0	250.0
OF12	12	27°	0.2 m	HFOV [m]		0.10	0.14	0.24	0.48	0.96	1.91	2.87	4.8	14.3	47.8
		20°		VFOV [m]		0.07	0.11	0.18	0.36	0.72	1.44	2.16	3.6	10.8	36.0
		33°		DFOV [m]		0.12	0.18	0.30	0.60	1.20	2.39	3.59	6.0	17.9	59.8
		1.25 mrad		IFOV [mm]		0.3	0.4	0.6	1.3	2.5	5.0	7.5	12.5	37.5	125.0
OF16	16	20°	0.2 m	HFOV [m]		0.07	0.11	0.18	0.36	0.72	1.43	2.15	3.6	10.7	35.8
		15°		VFOV [m]		0.05	0.08	0.14	0.27	0.54	1.08	1.62	2.7	8.1	27.0
		25°		DFOV [m]		0.09	0.13	0.22	0.45	0.90	1.79	2.69	4.5	13.5	44.9
		0.94 mrad		IFOV [mm]		0.2	0.3	0.5	0.9	1.9	3.8	5.6	9.4	28.1	93.8
OF25	25	13°	0.5 m	HFOV [m]	0.023	0.05	0.07	0.11	0.23	0.46	0.92	1.38	2.3	6.9	22.9
		10°		VFOV [m]	0.017	0.03	0.05	0.09	0.17	0.35	0.69	1.04	1.7	5.2	17.3
		16°		DFOV [m]	0.029	0.06	0.09	0.14	0.29	0.57	1.15	1.72	2.9	8.6	28.7
		0.60 mrad		IFOV [mm]	0.1	0.1	0.2	0.3	0.6	1.2	2.4	3.6	6.0	18.0	60.0
OF50	50	7°	1.5 m	HFOV [m]				0.06	0.11	0.23	0.46	0.69	1.1	3.4	11.5
		5°		VFOV [m]				0.04	0.09	0.17	0.35	0.52	0.9	2.6	8.6
		8°		DFOV [m]				0.07	0.14	0.29	0.57	0.86	1.4	4.3	14.4
		0.30 mrad		IFOV [mm]				0.2	0.3	0.6	1.2	1.8	3.0	9.0	30.0
OF75	75	4°	2.0 m	HFOV [m]					0.08	0.15	0.31	0.46	0.8	2.3	7.6
		3°		VFOV [m]					0.06	0.12	0.23	0.35	0.6	1.7	5.8
		5°		DFOV [m]					0.10	0.19	0.38	0.57	1.0	2.9	9.6
		0.20 mrad		IFOV [mm]					0.2	0.4	0.8	1.2	2.0	6.0	20.0

Optical data

OPTICS

PI 1M in VGA resolution 764 x 480 px	Focal length [mm]	Angle	Minimum measurement distance*	Distance to measurement object [m]											
					0,1	0,2	0,3	0,5	1	2	4	6	10	30	100
87° x 62°	6	87°	0.5 m	HFOV [m]				0.96	1.91	3.82	7.64	11.46	19.1	57.3	191.0
		62°		VFOV [m]				0.60	1.20	2.40	4.80	7.20	12.0	36.0	120.0
		97°		DFOV [m]				1.13	2.26	4.51	9.02	13.53	22.6	67.7	225.6
		2.50 mrad		IIFOV [mm]				1.3	2.5	5.0	10.0	15.0	25.0	75.0	250.0
51° x 33°	12	51°	0.2 m	HFOV [m]		0.19	0.29	0.48	0.96	1.91	3.82	5.73	9.6	28.7	95.5
		33°		VFOV [m]		0.12	0.18	0.30	0.60	1.20	2.40	3.60	6.0	18.0	60.0
		59°		DFOV [m]		0.23	0.34	0.56	1.13	2.26	4.51	6.77	11.3	33.8	112.8
		1.25 mrad		IIFOV [mm]		0.3	0.4	0.6	1.3	2.5	5.0	7.5	12.5	37.5	125.0
39° x 25°	16	39°	0.2 m	HFOV [m]		0.14	0.21	0.36	0.72	1.43	2.87	4.30	7.2	21.5	71.6
		25°		VFOV [m]		0.09	0.14	0.23	0.45	0.90	1.80	2.70	4.5	13.5	45.0
		46°		DFOV [m]		0.17	0.25	0.42	0.85	1.69	3.38	5.08	8.5	25.4	84.6
		0.94 mrad		IIFOV [mm]		0.2	0.3	0.5	0.9	1.9	3.8	5.6	9.4	28.1	93.8
26° x 16°	25	26°	0.5 m	HFOV [m]	0.046	0.09	0.14	0.23	0.46	0.92	1.83	2.75	4.6	13.8	45.8
		16°		VFOV [m]	0.029	0.06	0.09	0.14	0.29	0.58	1.15	1.73	2.9	8.6	28.8
		30°		DFOV [m]	0.054	0.11	0.16	0.27	0.54	1.08	2.17	3.25	5.4	16.2	54.1
		0.60 mrad		IIFOV [mm]	0.1	0.1	0.2	0.3	0.6	1.2	2.4	3.6	6.0	18.0	60.0
13° x 8°	50	13°	1.5 m	HFOV [m]				0.11	0.23	0.46	0.92	1.38	2.3	6.9	22.9
		8°		VFOV [m]				0.07	0.14	0.29	0.58	0.86	1.4	4.3	14.4
		15°		DFOV [m]				0.14	0.27	0.54	1.08	1.62	2.7	8.1	27.1
		0,30 mrad		IIFOV [mm]				0.2	0.3	0.6	1.2	1.8	3.0	9.0	30.0
9° x 5°	75	9°	2,0 m	HFOV [m]					0.15	0.31	0.61	0.92	1.5	4.6	15.3
		5°		VFOV [m]					0.10	0.19	0.38	0.58	1.0	2.9	9.6
		10°		DFOV [m]					0.18	0.36	0.72	1.08	1.8	5.4	18.0
		0.20 mrad		IIFOV [mm]					0.2	0.4	0.8	1.2	2.0	6.0	20.0

Specifications are subject to change without notice · Infrared cameras-BR-E2015-11-B

Optris GmbH
 Ferdinand-Buisson-Str. 14
 13127 Berlin · Germany
 Phone: +49 (0)30 500 197-0
 Fax: +49 (0)30 500 197-10
 E-mail: sales@optris.com
 www.optris.com

innovative infrared technology

